

PLP & PHP-2100 LOW & HIGH PROFILE PALLET STRETCH WRAP MACHINE

PHOENIX



PLP



**Standard
Control Panel**



PHP

Machine Specifications & Features

Control Feature

- PLC Control
- Nema Control Cabinet
- Keypad Settings
- Power On Pushbutton
- Emergency Stop
- “Start” Cycle
- Cycle Pause
- Manual Carriage Jog (Up & Down)
- Variable Carriage Travel Speed (Up & Down Separately)
- Photo-Eye “Auto Height” Sensing
- Spiral Up/Down Program
- Spiral Up Only Program
- VFD Motor Control
- Table Jog Control
- Variable Turntable Speed Adjustment
- Film Force to Load(Film Tension) Control
- Separate Top & Bottom Wrap Counters (1-10)

Film Delivery System

- 20” Powered Pre-Stretch
- Up to 300% Pre-Stretch Capability
- Adjustable Electronic Film Force Control
- Mechanical Film Force Adjustment (To Increase or Decrease Minimum Force Setting)
- True Linear Solid State Film Feed Sensor
- Auto-Shutoff of the Pre-Stretch for Greater Safety
- Operator Access Door for Loading

Carriage Lift

- UHMV-PE Carriage Rollers for Smooth Maintenance Free Operations
- ANSI Chain Lift System Self Adjusting (Needs No Maintenance)
- 230VAC Motor
- Synthetic Oil Filled Reducer

Turntable Drive

- 230VAC Motor Control
- Positive Turntable Alignment
- Electronic Soft Start (VFD)
- #50 ANSI Chain Drive for Low Maintenance & Reliable Operations

Low Profile (PLP) Features

- 20 H.D.** Table Support Casters. **No Lubrication Required**
- One of the Lowest Turntable Elevations in the Industry at **27/8”** to Ease Operator Loading/Unloading Via Palletjack
- 3/8” Thick Turntable
- Compact Design Saves Space
- Forklift Portable From the Front of Machine
- Optional Ramps for Regular & H.D. Applications

High Profile (PHP) Features

- 5 H.D. Support Casters on Welded Supports
- Welded Octagonal Table for Maximum Strength
- 8 3/4” Table Height
- Forklift Portable from The Front & Back of Machine

Technical Information

- | | |
|--|---|
| Power: | 120VAC, 1 Phase, 60Hz.
15 AMPS Dedicated Line |
| Table Speed: | 14 RPM |
| Max. Load Weight: | 4000 Lbs. |
| Max Load Size: | 56”W x 56”L (80” Load Diagonal) |
| Shipping Weight: | 895 Lbs. (PHP), 925 Lbs. (PLP)
285 Lbs. (Ramp) |
| CSA/UL Listed Components/Operator manual | |

PLP & PHP-2100 LOW & HIGH PROFILE PALLET STRETCH WRAP MACHINE



The PHOENIX "2100" Series Advantage

The High and Low Profile "2100" Series machines were developed to provide performance at an affordable price. Despite its compact design and basic appearance, the "2100" Series is robust in construction, easy to install, operate, and simple to maintain. It is equipped with sophisticated and comprehensive controls., with features normally found only on more expensive models. Features such as Photo-eye-Auto-Load Height Detection and Soft Start. A powered Prestretch for economical and cost effective operations. The ergonomic positioning of the film carriage and control panel make it easy for an operator to manipulate the film for special applications. The carriage is easy to load, simple and safe to operate. The turntable supports on both machines are designed for smooth and quiet operation in rugged every day use. Welded table caster supports provide greater strength and durability. All major components are quickly accessible for easy maintenance and service. The compact design helps meet the needs of customers with limited floor space. A solid "workhorse" at an "entry" level price.

Phoenix quality you have come to depend on at an affordable price.

Low Profile PLP-2100 Dimensions

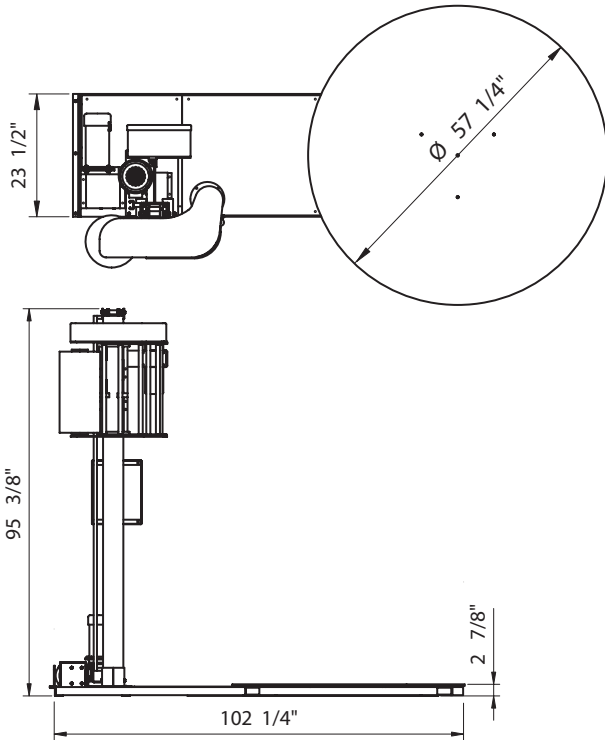

PLP-2100 Wrap Height (with 8 ft. Tower) : 80"

Maximum Load Size: 56" x 56" (80" Diag.)

High Profile PHP-2100 Dimensions

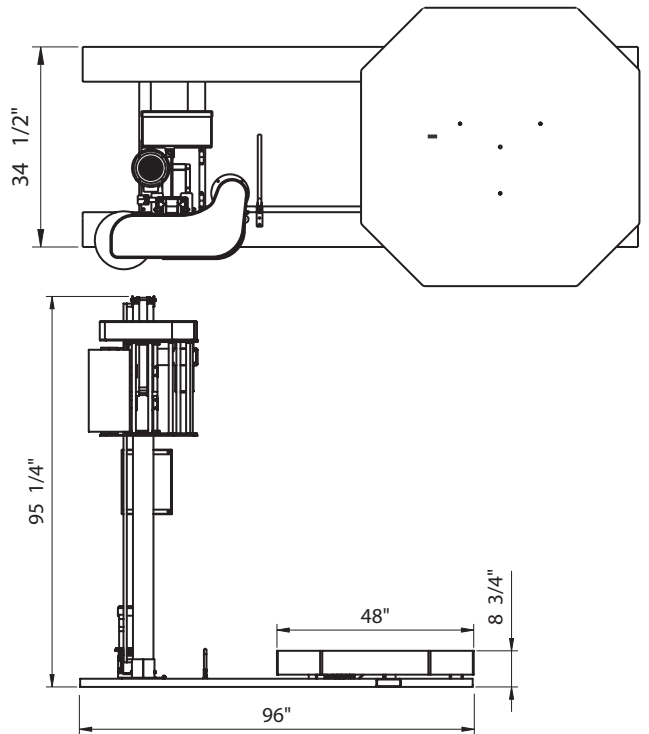

PHP-2100 Wrap Height (with 8 ft. Tower) : 80"

Maximum Load Size : 56" x 56" (80" Diag.)

Distributed By: